

CS 5523 Lecture 26: Naming

- *Questions on Laboratory 4*
- *Additional comments on Farsite from previous lecture*
- *Basic terminology*
- *Name spaces*
- *Name service goals*
- *Navigation*
- *DNS*

Basic naming terminology

- *name - something that identifies an entity*
- *pure name - uninterpreted bit pattern*
- *non-pure name - contains information about the entity*
- *address - location of an entity*
- *resolving a name - when a name is translated into information about the entity in order to invoke an action on it*
- *binding - association between name and information about entity*

Examples of binding

- *DNS - maps domain names to host attributes (IP address, type of service, time-to-live)*
- *X500 - a directory service that maps a person's name to attributes (email address, etc.)*
- *CORBA Naming and Trading Service - maps the name of a remote to reference and object description*

Figure 9.1
Composed naming domains used to access a resource from a URL

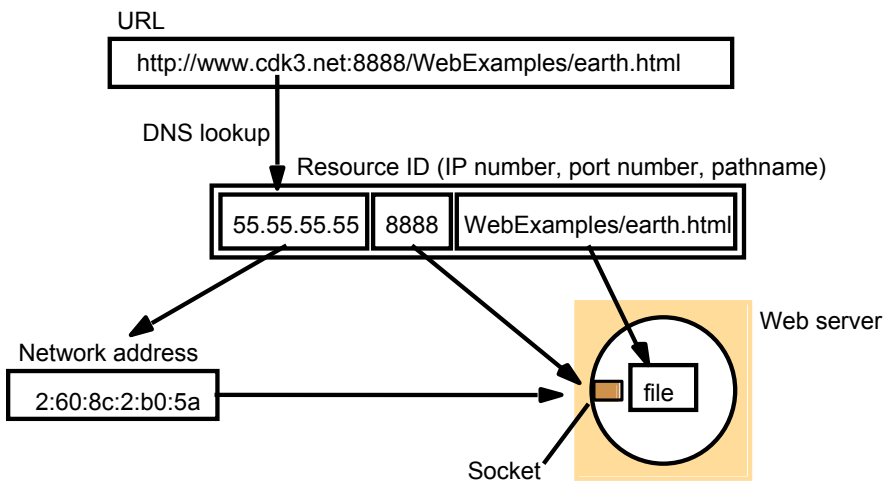

Name service basics

- *a name service stores one or more naming contexts and responds to requests regarding these contexts*
- *a naming context is a set of textual names and attributes*
- *a name space is a collection of valid names recognized by a name service*
- *a naming domain is a name space which has a single administrative authority*

What operations should a name service have?

Why is name management usually separated from other services?

Name spaces in DNS

- *hierarchical structure - one or more components or labels separated by periods (.)*
- *only absolute names - referred relative to global root*
- *clients usually have a list of default domains that are appended to single-component domain names before trying global root*
- *allows aliases such as `www.utsa.edu`*

Compare name spaces in DNS with Unix file names.

Name service goals:

- *scalable to arbitrary size*
- *have a long lifetime*
- *be highly available*
- *have fault isolation*
- *tolerate mistrust*

Navigation of name services:

- *name spaces are usually partitioned and cannot be serviced by a single server*
- *navigation - process of locating naming data from a collection of name servers in order to resolve a name*

Types of navigation:

- *iterative* - result of query immediately returned to client (with a hint of where to look next if query failed)
- *multicast* - client simultaneously queries a group of servers and waits for the first response
- *non-recursive server-controlled* - client chooses a server who provides iterative navigation on its behalf
- *recursive server-controlled* - servers recursively contact other servers until name is resolved.

Figure 9.2
Iterative navigation

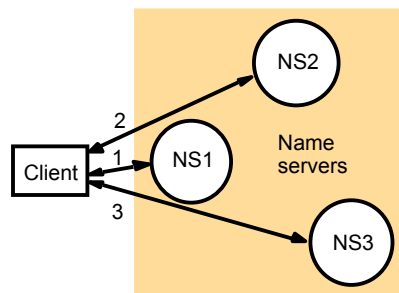

A client iteratively contacts name servers NS1–NS3 in order to resolve a name

Figure 9.3
Non-recursive and recursive server-controlled navigation

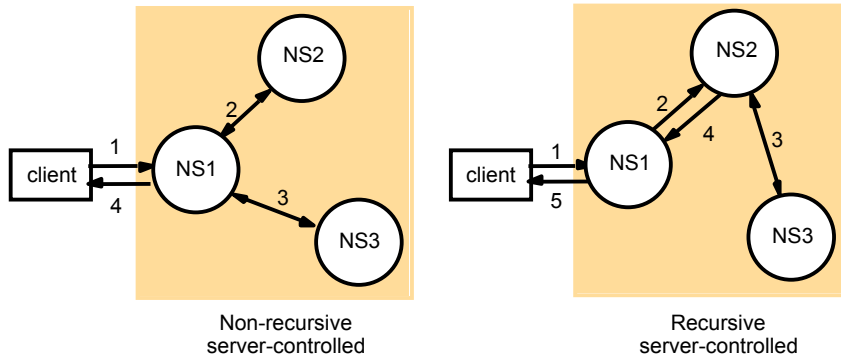

A name server NS1 communicates with other name servers on behalf of a client

DNS - domain name system:

- *replaced a single master file scheme*
- *devised by Mockapetris (1987)*
- *objects are names of computers*
- *attributes are IP addresses*
- *scaling is achieved by a combination of*
 - *hierarchical partitioning*
 - *replication of naming data*
 - *caching*

Domain names (last element of hierarchical name):

- *com - commercial organizations*
- *edu - universities and educational institutions*
- *gov - US government agencies*
- *mil - US military organizations*
- *net - major network support centers*
- *org - organizations not included in first five*
- *int - international organization*
- *country codes - (e.g., us, uk, fr, etc.)*

New domain names (approved by ICANN 11/2000):

- *aero - air transportation industries*
- *biz - businesssees*
- *coop - cooperatives*
- *info - unrestricted*
- *museum - museums*
- *name - individuals*
- *pro - professions such as doctors and lawyers*

DNS queries:

- *host resolution - resolves host names into IP addresses*
- *mail host location - resolves domain names into IP addresses of mail hosts*
- *reverse resolution - returns a host name given an IP address*
- *host information - given a host name, return information about the host*
- *well-known services - return a list of services given a hostname*

Give an example of a use of each of these types of queries.

Zone partitioning of the DNS name space:

- *zone - contains attribute data for names in domain minus the sub-domains administrated by lower-level authorities:*
 - Example: UTSA has a name server for utsa.edu, but cs.utsa.edu names are resolved by the CS Department server*
- *at least two name servers that provide authoritative data for the zone*
- *names of the servers for the sub-domains*
- *zone management parameters*

Authoritative name servers:

- *a server may be an authoritative source for zero or more zones*
- *data for a zone is entered into a local master file*
- *the master (primary) server reads the zone data directly from the master file*
- *secondary authoritative servers download zone data from primary server*
- *secondary servers periodically check their version number against the master server*

Caching in DNS:

- *any server can cache any name*
- *non-authoritative servers note time to live when they cache data*
- *non-authoritative servers indicate that they are such when responding to clients with cached names*

Figure 9.4
DNS name servers

Note: Name server names are in italics, and the corresponding domains are in parentheses. Arrows denote name server entries

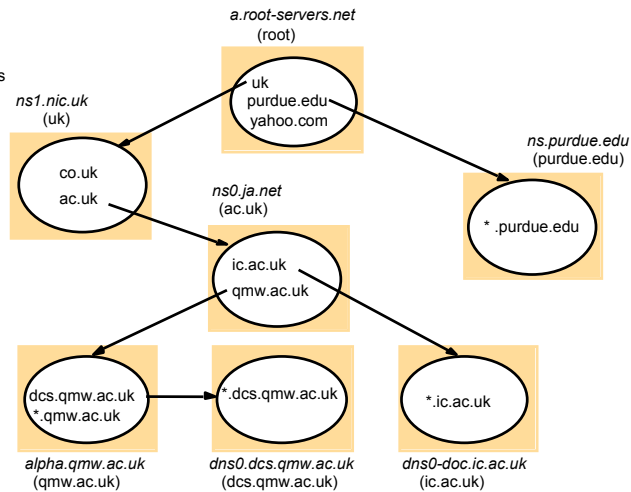

Instructor's Guide for Coulouris, Dollimore and Kindberg Distributed Systems: Concepts and Design Edn. 3
© Addison-Wesley Publishers 2000

DNS clients (resolvers):

- Resolvers are usually implemented as library routines (e.g., `gethostbyname`).
- The request is formatted into a DNS record.
- DNS servers use a well-known port.
- A request-reply protocol is used.
- The resolver times out and resends if it doesn't receive a response in a specified time.

Figure 9.5
DNS resource records

<i>Record type</i>	<i>Meaning</i>	<i>Main contents</i>
A	A computer address	IP number
NS	An authoritative name server	Domain name for server
CNAME	The canonical name for an alias	Domain name for alias
SOA	Marks the start of data for a zone	Parameters governing the zone
WKS	A well-known service description	List of service names and protocols
PTR	Domain name pointer (reverse lookups)	Domain name
HINFO	Host information	Machine architecture and operating system
MX	Mail exchange	List of <preference, host> pairs
TXT	Text string	Arbitrary text

Layout of a DNS database:

- *SOA - giving zone parameters*
- *NS records - giving name servers for domain*
- *MX records - giving mail host names*

For next time:

- *Read Stevens I Chapter 9*

- *Print man pages for resolver:*

```
man resolver | mpage -2 | lp
```